

# AXF

AXLES DIVISION

/// IT /// FR

CATALOGO / Catalogue **2019**

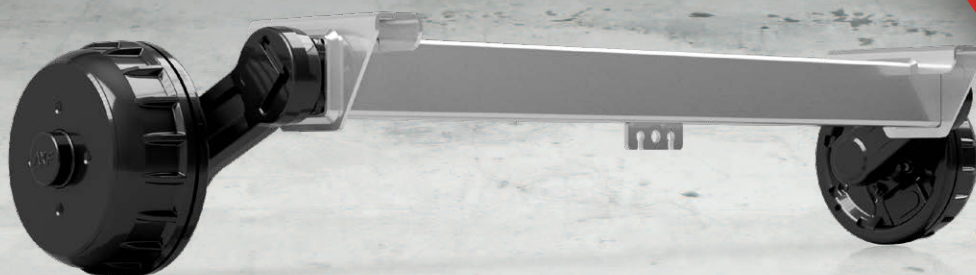

# FRENCO

# INDICE / SOMMAIRE

**4** / **COME SCEGLIERE UN ASSALE**  
COMMENT CHOISIR UN ESSEU

**5** / **ASSALI E SEMIASSALI FRENATI E NON FRENATI**  
ESSEUX ET DEMI-ESSEUX FREINÉS ET NON FREINÉS

**10** / **STAFFE**  
ÉTRIERS

**11** / **ATTACCHI RUOTA**  
FIXATION DES ROUES

**12** / **CAVI FRENO**  
CÂBLES DE FREIN

**15** / **ATTACCHI SFERICI**  
BOITES À ROTULE

**16** / **REPULSORI**  
DISPOSITIFS À INERTIE

**18** / **RUOTINI**  
ROUES JOCKEY

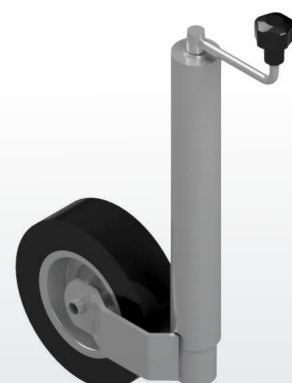
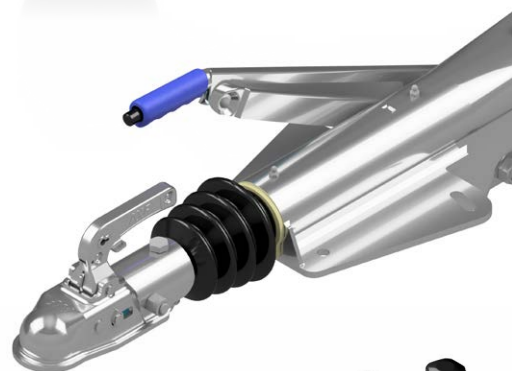
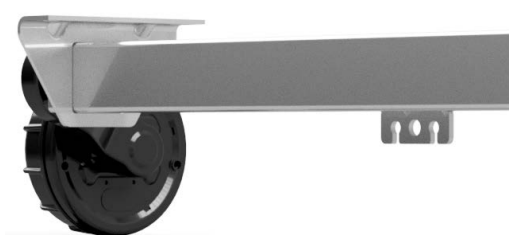



**AXLES DIVISION**

**AXF, LA DIVISIONE FRENCO SPECIALIZZATA  
NELLA PRODUZIONE DI ASSALI, SISTEMI FRENANTI E REPULSORI.**

FRENCO è leader nella produzione di masse frenanti per rimorchi agricoli.  
Dal 2010, con l'acquisizione di uno storico brand italiano, nasce il marchio AXF.  
AXF produce assali a torsione, sistemi di frenatura ad inerzia e repulsori.  
AXF si pone nel mercato nazionale e internazionale come partner di fiducia,  
garantendo esperienza, qualità, personale qualificato, puntualità di servizio e competitività.

**I PRODOTTI AXF SONO TUTTI MADE IN ITALY.**

**AXF, LA DIVISION FRENCO SPÉCIALISÉE  
DANS LA PRODUCTION D'ESSIEUX, DE CIRCUITS DE FREINAGE ET DE TIMONS**

FRENCO est leader dans la production de parties freinantes pour remorques agricoles.  
En 2010, suite à l'acquisition d'une marque italienne historique naît la marque AXF.  
AXF produit des essieux à torsion, des circuits de freinage et des timons.  
AXF se positionne sur le marché national et international comme partenaire de confiance, en mesure  
de garantir l'expérience, la qualité, le personnel qualifié, la ponctualité de service et la compétitivité.

**LES PRODUITS AXF SONT TOUS MADE IN ITALY.**

**FRENCO**

## COME SCEGLIERE UN ASSALE

### DIMENSIONI PER LA SCELTA DI UN ASSALE FRENATO O NON FRENATO

#### PORTATA NOMINALE

La portata nominale a catalogo è il carico massimo ammesso per assale.

Il catalogo fornisce delle linee guida basilari per la scelta di un assale. I dettagli finali necessari per la scelta definitiva di un determinato assale andranno approfonditi con il supporto del nostro dipartimento tecnico.

La seguente sezione "Come scegliere un assale" vi fornirà le informazioni necessarie per individuare il prodotto adatto alla vostra applicazione.

#### COME SCEGLIERE UN ASSALE

Per identificare il tipo di assale a voi necessario, dovrete considerare i seguenti dati:

1. Frenato o non frenato
2. Portata
3. Attacco ruota
4. Interasse staffe, quota "A"
5. Carreggiata, quota "B"
6. Asse singolo o due assali (tandem)

Su richiesta: attacco ruota non standard, inclinazione bracci diversi.

Per qualsiasi chiarimento non esitate a contattare il nostro ufficio tecnico.

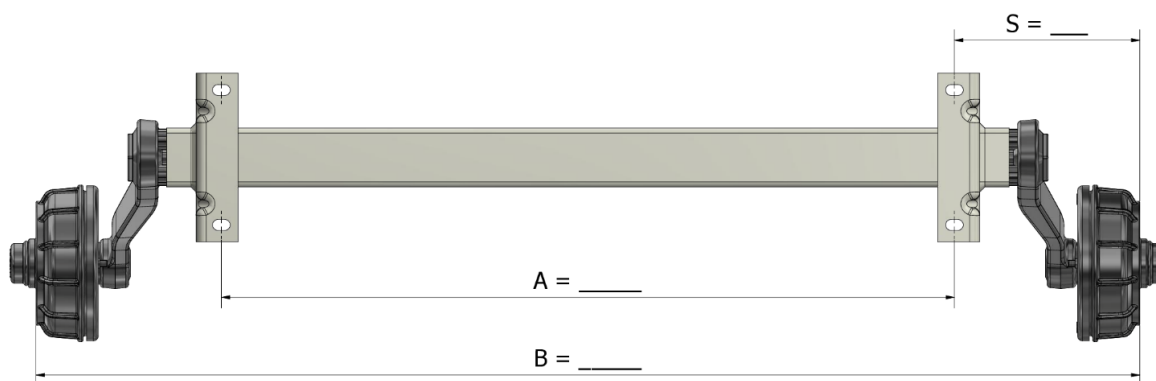

## COMMENT CHOISIR UN ESSIEU

### DIMENSIONIS POUR LE CHOIX D'UN ESSIEU FREINÉ OU NON FREINÉ

#### PORTÉE NOMINALE

La portée nominale indiquée sur le catalogue représente la charge maximum admise par essieu.

Le catalogue fournit des lignes directrices de base pour le choix d'un essieu. Les détails finaux nécessaires au choix définitifs d'un essieu particulier seront approfondis avec le support de notre service technique.

La section suivante "Comment choisir un essieu" vous fournira les informations nécessaires pour trouver le juste produit répondant à votre utilisation.

#### COMMENT CHOISIR UN ESSIEU

Afin d'identifier le type d'essieu dont vous avez besoin, vous devrez tenir compte des données suivantes :

1. Freiné ou non freiné
2. Capacité de charge
3. Perçage / fixation
4. EAB, cote "A"
5. Voie, cote "B"
6. Essieu simple ou double (tandem)

Sur demande: perçage non standard, inclinaison différente des bras.

Pour toute explication nécessaire, n'hésitez pas à contacter notre bureau technique.



ASSALI E SEMIASSALI  
FRENATI  
E NON FRENATI

ESSIEUX ET  
DEMI-ESSIEUX  
FREINÉS ET  
NON FREINÉS

**AXF**

AXLES DIVISION

## ASSALI FRENATI ESSIEUX FREINÉS

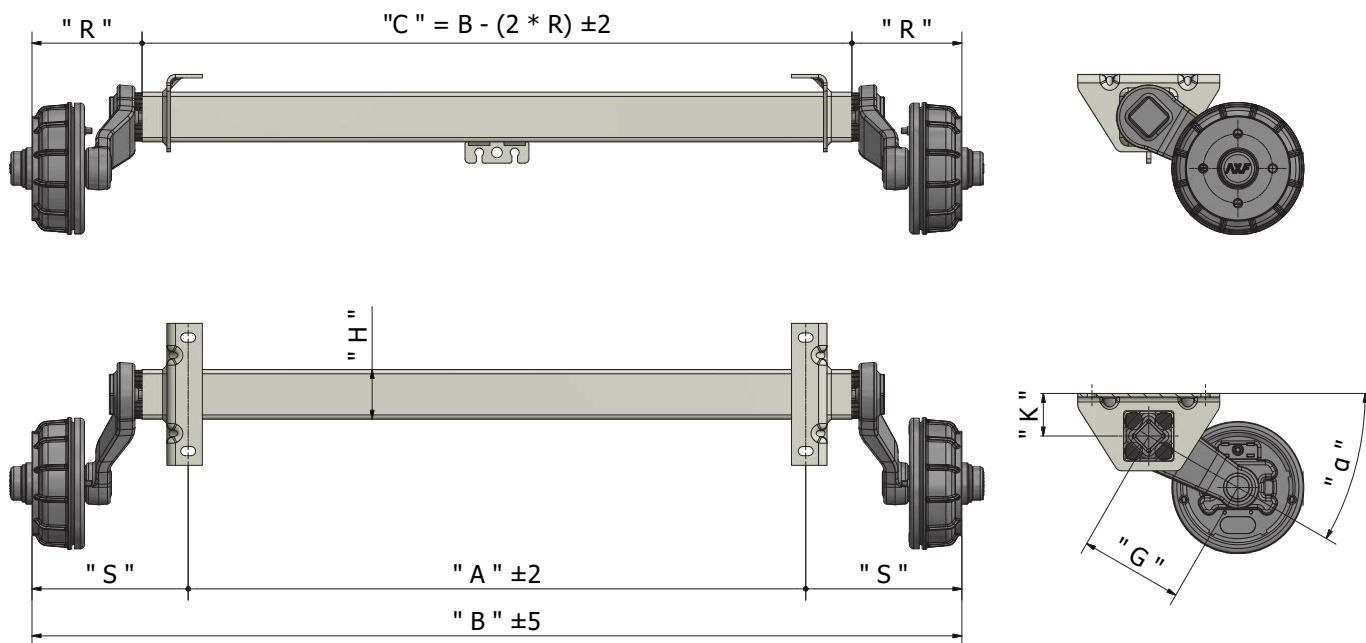

### ASSALI FRENATI ESSIEUX FREINÉS

PORTATA CAPACITÀ de charge	FRENO FREIN	$\alpha$	G	K	A min	B min	OFFSET* DÉPORT*	H	R	S min	S max	STAFFE ÉTRIER	ATTACCO** FIXATION DES ROUES**
750	160x35	22°	145	60	390	1020	0/+30	Q60	155	140	315	A	056 - 058 - 066
1000	160x35	30°	145	60	290	1030	0/+30	Q70	155	140	370	A	056 - 058 - 066
1500	200x50	30°	160	60	540	1300	+15/+40	Q80	185	225	380	B	058 - 066 - NS - 093
1800	250x40	30°	160	60	450	1320	+20/+45	Q80	195	240	435	B	066 - NS - 093 - LR
2500	250x60	30°	200	55	880	1520	10/+30	Q100	200	245	320	C	NS - LR - 093 - 160
3500	305x80	30°	200	55 / 70	880	1520	-10/+20	Q100	200	245	320	C / D	160

\* CONSIGLIATO / CONSEILLÉ

\*\* ALTRI ATTACCHI DISPONIBILI SU RICHIESTA / AUTRES FIXATIONS DISPONIBLES SUR DEMANDE  
ALTRE PORTATE DISPONIBILI SU RICHIESTA / AUTRES CHARGES DISPONIBLES SUR DEMANDE

Tutte le dimensioni sono in millimetri / Toutes les dimensions sont indiquées en millimètres

STAFFE vedi pag. 10 / ÉTRIER, voir page 10

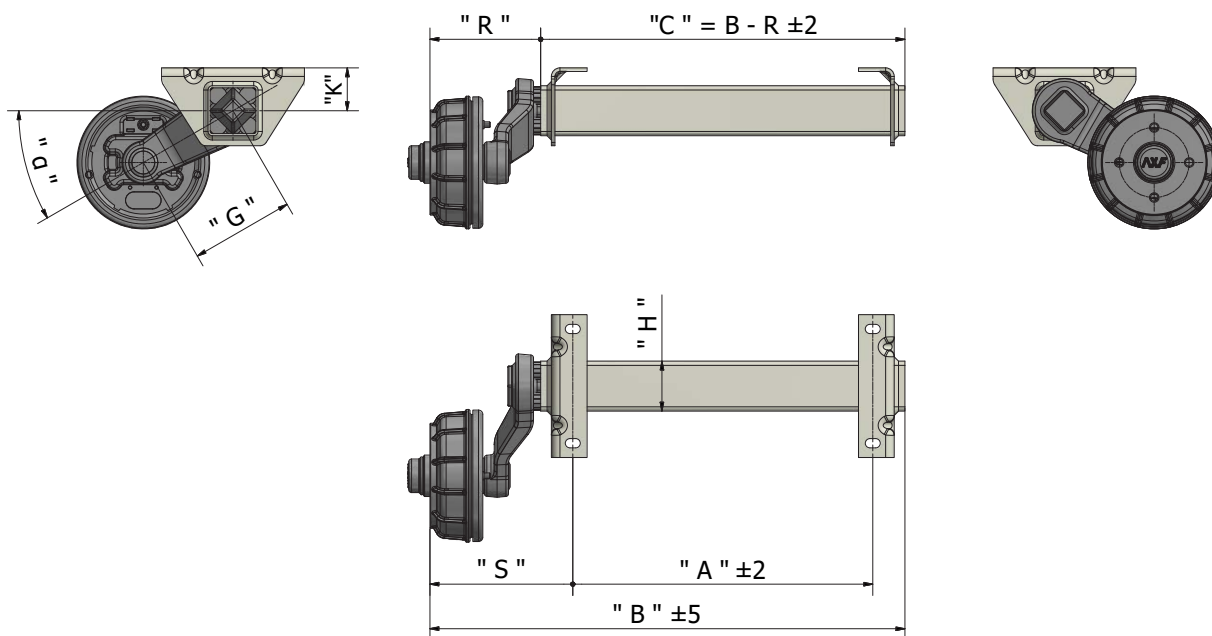

**SEMIASSALI FRENATI** DEMI-ESSIEUX FREINÉS

PORTATA CAPACITÉ de charge	FRENO FREIN	$\alpha$	G	K	A min	B min	OFFSET * DÉPORT *	H	R	S min	S max	STAFFE ÉTRIER	ATTACCO** FIXATION DES ROUES**
<b>375</b>	160x35	22°	145	60	/	520	0/+30	Q60	155	130	315	A	056 - 058 - 066
<b>500</b>	160x35	30°	145	60	/	530	0/+30	Q70	155	130	330	A	056 - 058 - 066
<b>750</b>	200x50	30°	160	60	/	660	+15/+40	Q80	185	230	380	B	058 - 066 - NS - 093
<b>900</b>	250x40	30°	160	60	/	670	+20/+45	Q80	195	240	435	B	066 - NS - 093 - LR
<b>1250</b>	250x60	30°	200	55	/	770	10/+30	Q100	200	240	320	C	NS - LR - 093 - 160
<b>1750</b>	305x80	30°	200	55 / 70	/	770	-10/+20	Q100	200	240	320	C / D	160

\* CONSIGLIATO / CONSEILLÉ

\*\* ALTRI ATTACCHI DISPONIBILI SU RICHIESTA / AUTRES FIXATIONS DISPONIBLES SUR DEMANDE  
ALTRE PORTATE DISPONIBILI SU RICHIESTA / AUTRES CHARGES DISPONIBLES SUR DEMANDE

Tutte le dimensioni sono in millimetri / Toutes les dimensions sont indiquées en millimètres

STAFFE vedi pag. 10 / ÉTRIERS, voir page 10



## ASSALI NON FRENATI ESSIEUX NON FREINÉS

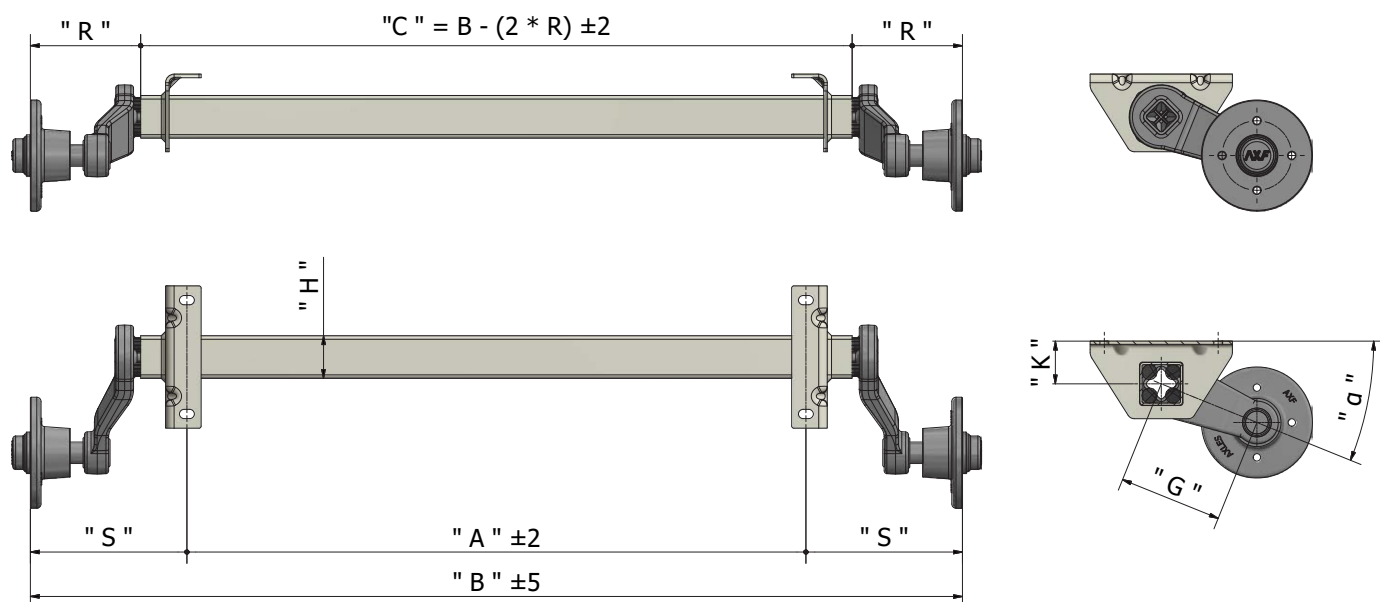

### ASSALI NON FRENATI ESSIEUX NON FREINÉS

PORTATA CAPACITÉ de charge	$\alpha$	G	K	A min	B min	OFFSET* DÉPORT*	H	R	S min	S max	STAFFE ÉTRIER	ATTACCO** FIXATION DES ROUES**
500	30°	145	60	200	820	0/+30	Q55	145	130	310	A	056 - 058
750	22°	145	60	400	1030	0/+30	Q60	150	140	315	A	056 - 058
900	22°	145	60	280	1020	+20/+30	Q60	155	145	370	A	056 - 058 - 066

\* CONSIGLIATO / CONSEILLÉ

\*\* ALTRI ATTACCHI DISPONIBILI SU RICHIESTA / AUTRES FIXATIONS DISPONIBLES SUR DEMANDE  
ALTRE PORTATE DISPONIBILI SU RICHIESTA / AUTRES CHARGES DISPONIBLES SUR DEMANDE  
Tutte le dimensioni sono in millimetri / Toutes les dimensions sont indiquées en millimètres  
STAFFE vedi pag. 10 / ÉTRIERS, voir page 10





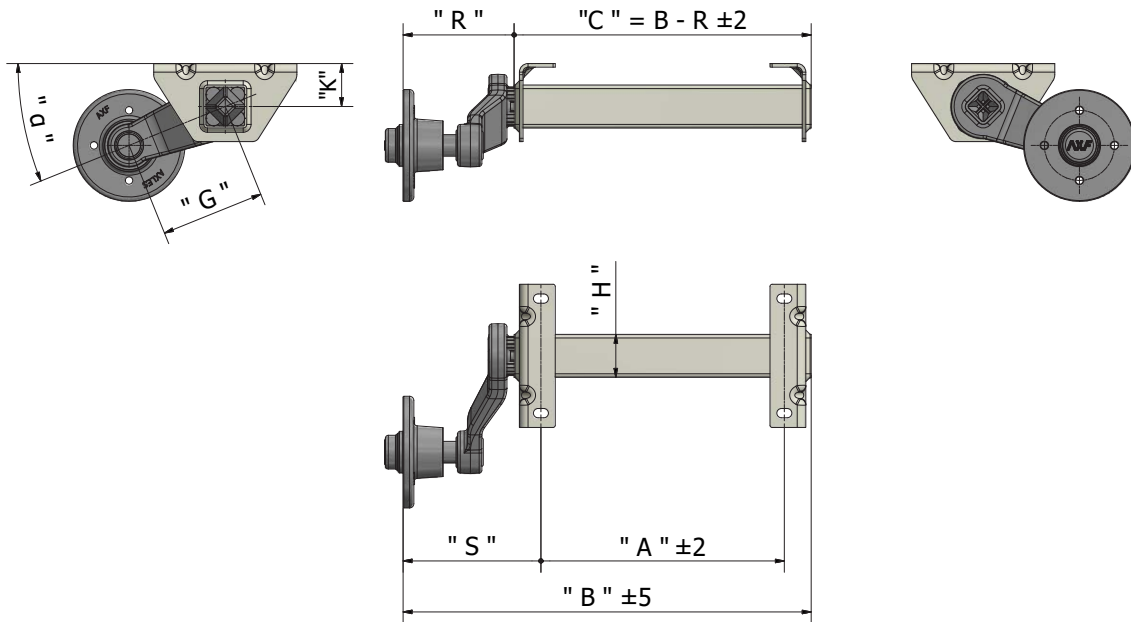

**SEMIASSALI NON FRENATI** DEMI-ESSIEUX NON FREINÉS

PORTATA CAPACITÉ de charge	$\alpha$	G	K	A min	B min	OFFSET* DÉPORT*	H	R	S min	S max	STAFFE ÉTRIER	ATTACCO** FIXATION DES ROUES**
250	30°	145	60	/	420	0/+30	Q55	145	120	310	A	056 - 058
375	22°	145	60	/	530	0/+30	Q60	155	130	315	A	056 - 058
450	22°	145	60	/	520	+20/+30	Q60	155	130	370	A	056 - 058 - 066

\* CONSIGLIATO / CONSEILLÉ

\*\* ALTRI ATTACCHI DISPONIBILI SU RICHIESTA / AUTRES FIXATIONS DISPONIBLES SUR DEMANDE  
ALTRE PORTATE DISPONIBILI SU RICHIESTA / AUTRES CHARGES DISPONIBLES SUR DEMANDE  
Tutte le dimensioni sono in millimetri / Toutes les dimensions sont indiquées en millimètres  
STAFFE vedi pag. 10 / ÉTRIERS, voir page 10

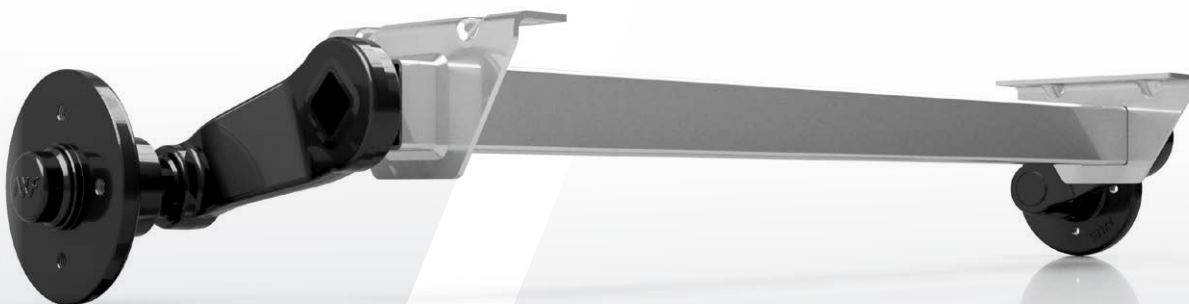

# STAFFE ÉTRIERS

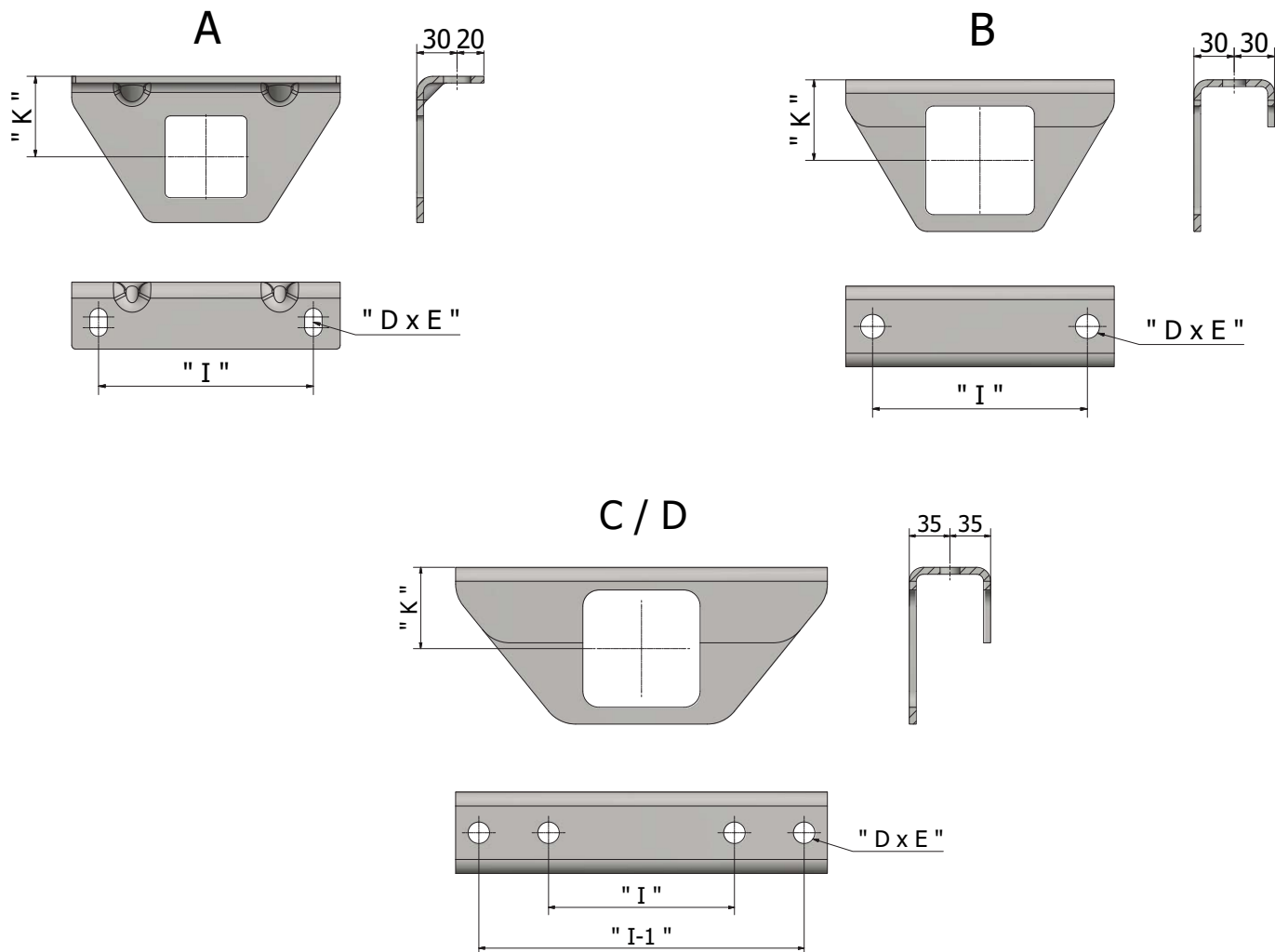

## STAFFE ÉTRIERS

RIF. RÉF.	I	I-1	K	DxE
A	160	/	60	21x13
B	160	/	60	18
C	160	280	55	18,5
D	160	280	70	18,5

Tutte le dimensioni sono in millimetri / Toutes les dimensions sont indiquées en millimètres



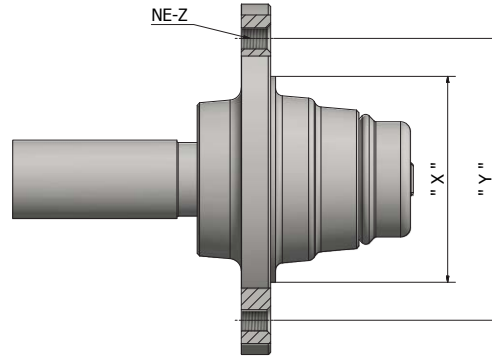
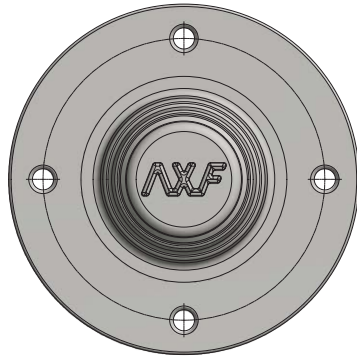

**ATTACCHI RUOTA** FIXATION DES ROUES

TIPO FISSAGGIO TYPE FIXATION		X x Y / NE-Z	VITE Z x L VIS Z x L	DADO ÉCROU	MARCHIO MARQUE
A	056	56x100/4-M12 Conical seat 60°	Conical screw ring M12x1,5x24		OPEL BMW VOLKSWAGEN
B	058	58x98/4-M12 Conical seat 60°	Conical screw ring M12x1,5x24		FIAT SEAT
C	066	66x112/5-M12 Conical seat 60°	Spherical screw ring M12x1,5x24		MERCEDES
D	NV	66X114,3/4-M12 Conical seat 60°	Conical screw ring M12x1,5x24		NISSAN VANETTE
E	JC	71X114,3/5-M14 Conical seat 60°	Conical screw ring M14x1,5x24		JEEP CHEROKEE
F	84	84X115/4-M10 Conical seat 60°	Conical screw ring M10x1,25x24		/
G	84	84X130/4-M14 Conical seat 60°	Conical screw ring M14x1,5x24		NAUTILUS
H	NS	99X139,7/6-M12 Conical seat 60°	Conical screw ring M12x1,5x24		NISSAN TERRANO NISSAN PATROL
L	SK	107X139,7/5-M12 Conical seat 60°	Conical screw ring M12x1,5x24		SUZUKI
M	DKW	84X140/5-M16 Conical seat 60°	Stud M16x1,5x42	Conical nut M16x1,5	DKW MERCEDES
N	93	93X140/5-M14 Spherical seat R16	Conical screw ring M14x1,5x24		INTERNATIONAL
N	LN	94X140/5-M14 Conical seat 60°	Conical screw ring M14x1,5x24		LADA NIVA
P	LR	114,3X165,1/5-M16 Conical seat 60°	Stud M16x1,5x42	Conical nut M16x1,5	LAND ROVER
Q	160	160X205/6-M18 Spherical seat R16	Stud M18x1,5x49	Spherical nut M18x1,5	/
X	NO STD		Disponibile su richiesta - Disponible sur demande		

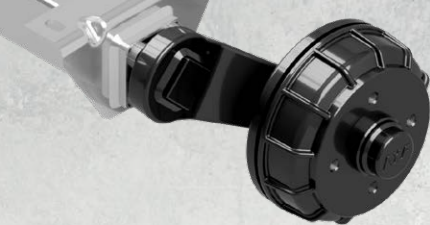

## CAVI FRENO ASSE SINGOLO

### CÂBLES DE FREIN ESSIEU SIMPLE

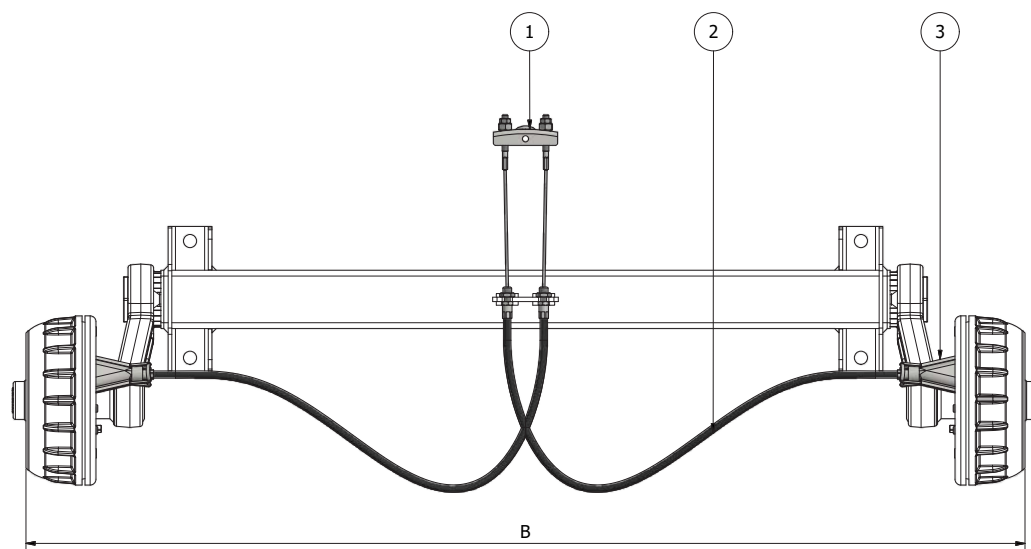

## CAVI FRENO ASSE SINGOLO CÂBLES DE FREIN ESSIEU SIMPLE

CODICE CODE	DESCRIZIONE DESCRIPTION	LUNGHEZZA GUAINA LONGUEUR GAINÉ	CARREGGIATA VOIE	
KT27F04591	KIT FUNI SFD-750	750	0	1450
KT27F04553	KIT FUNI SFD-900	900	1451	1700
KT27F04592	KIT FUNI SFD-1050	1050	1701	2000
KT27F04593	KIT FUNI SFD-1200	1200	2001	2400
KT27F04395	KIT FUNI SFD-1300	1300	2400	/

Tutte le dimensioni sono in millimetri / Toutes les dimensions sont indiquées en millimètres

- 1 BILANCIERE - PALONNIER
- 2 TIRANTE - TIRANT
- 3 MEZZO CONO - DEMI-CÔNE

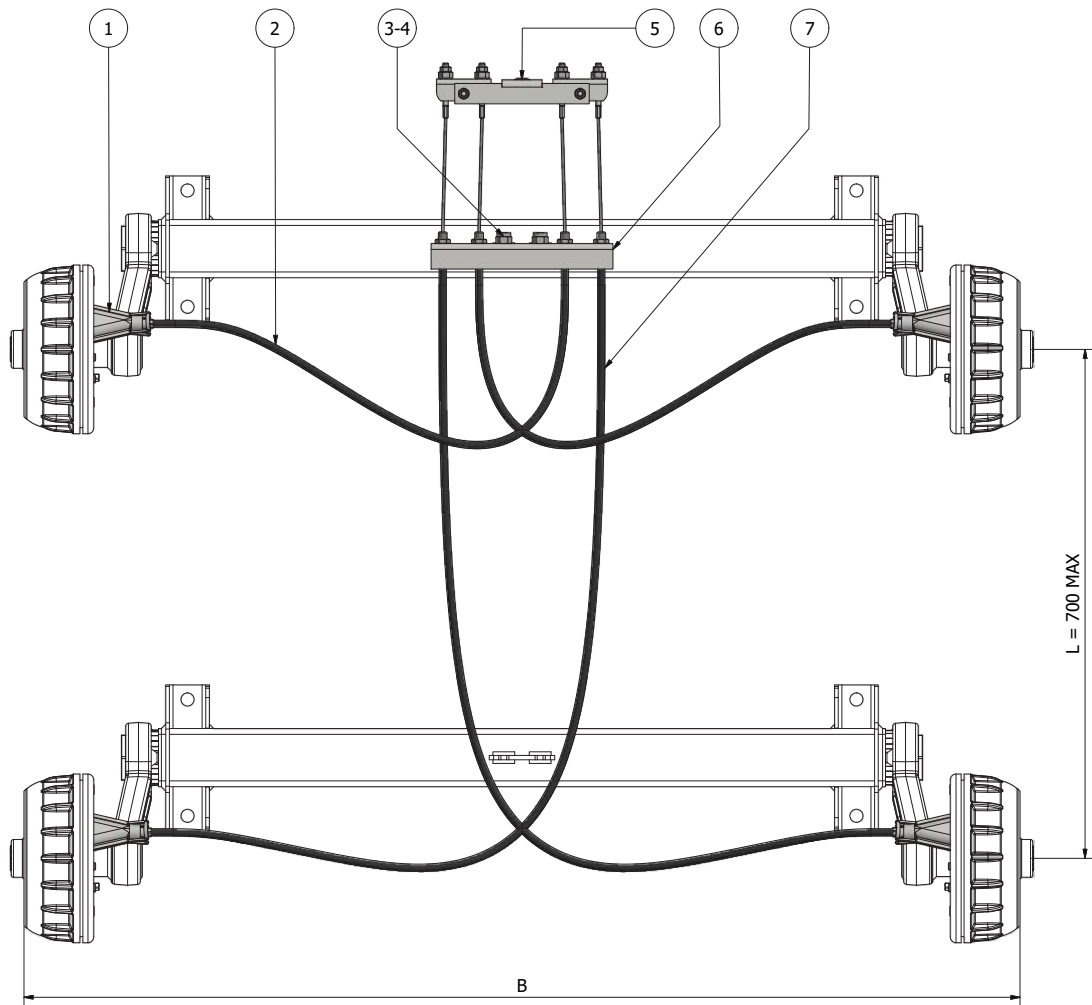

**CAVI FRENO ASSALI IN TANDEM** CÂBLES DE FREIN ESSIEUX EN TANDEM

CODICE CODE	DESCRIZIONE DESCRIPTION	LUNGHEZZA GUAINA LONGUEUR GAINÉ		CARREGGIATA VOIE	
		ANTERIORE AVANT	POSTERIORE ARRIÈRE		
KT27F04594	KIT FUNI TANDEM SFD-750/1200	750	1200	0	1450
KT27F04754	KIT FUNI TANDEM SFD-900/1300	900	1300	1451	1700
KT27F04755	KIT FUNI TANDEM SFD-1050/1480	1050	1480	1701	2000
KT27F04812	KIT FUNI TANDEM SFD-1200/1600	1200	1600	2001	2400
KT27F04823	KIT FUNI TANDEM SFD-1480/1750	1480	1750	2601	/

Tutte le dimensioni sono in millimetri / Toutes les dimensions sont indiquées en millimètres

- 1 MEZZO CONO - DEMI-CÔNE
- 2 TIRANTE ANTERIORE - TIRANT AVANT
- 3,4 VITI DADI - VIS ÉCROUS
- 5 BILANCIERE - PALONNIER
- 6 PIASTRA - PLAQUE
- 7 TIRANTE POSTERIORE - TIRANT ARRIÈRE



# ATTACCHI SFERICI REPULSORI RUOTINI

BOITES À ROTULE  
DISPOSITIFS À INERTIE  
ROUES JOCKEY

# AXF

AXLES DIVISION

Fig. "1"

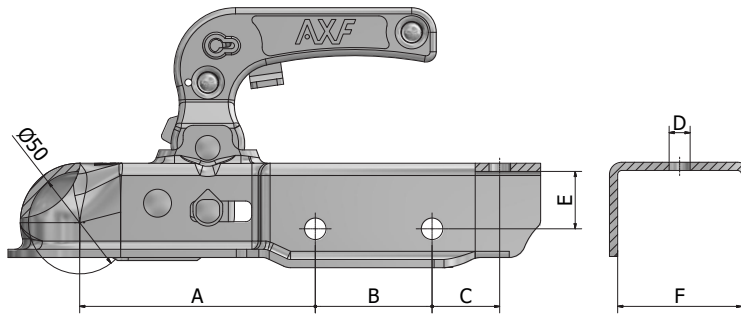

Fig. "2"

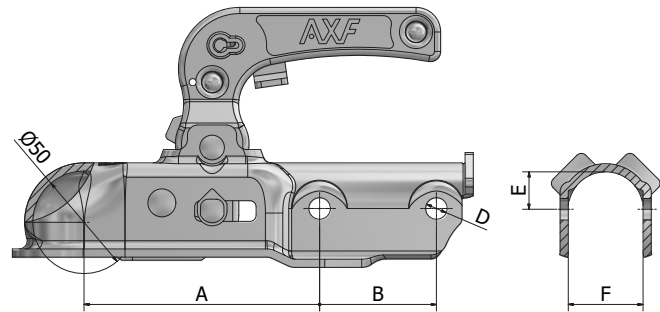
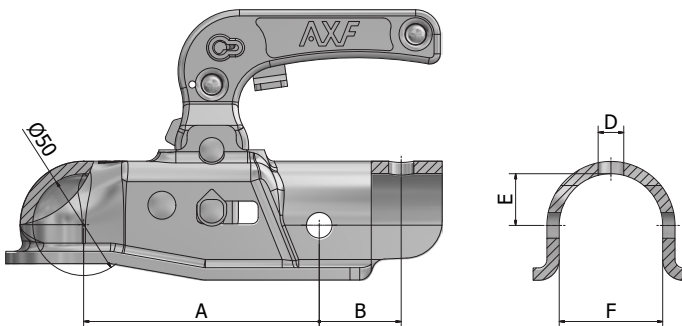
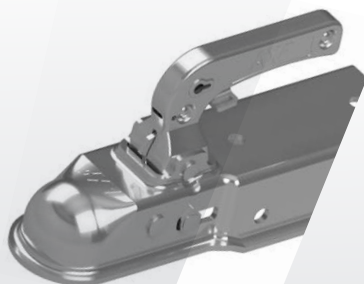

Fig. "3"



**ATTACCHI SFERICI** BOITES À ROTULE

CODICE CODE	TIPO TYPE	FIG.	PORTATA CAPACITÉ de charge [Kg]	"S" [Kg]	"D" [Kn]	A [mm]	B [mm]	C [mm]	D [mm]	E [mm]	F [mm]	N. OMOLOGAZIONE N° HOMOLOGATION
7110A06236	GE 10-5	1	1000	75	9,6	115	57	33	10,5	/	50,5	55R-016475
7110A06237	GE 10-6	1	1000	75	9,6	115	57	33	10,5	25	60,5	55R-016475
7110A06238	GE 10-T	2	1000	75	9,6	115	57	/	10,5	18,5	36,5	55R-016475
7115A06239	GE 15-T	2	1500	100	14,1	115	57	/	10,5	18,5	36,5	55R-016477
7128A06240	GE 25-T	3	2800	120	25,26	115	40	/	12,5	25,25	50,50	55R-016476



## REPULSORE QUADRO

### DISPOSITIFS À INERTIE TIMON DROIT

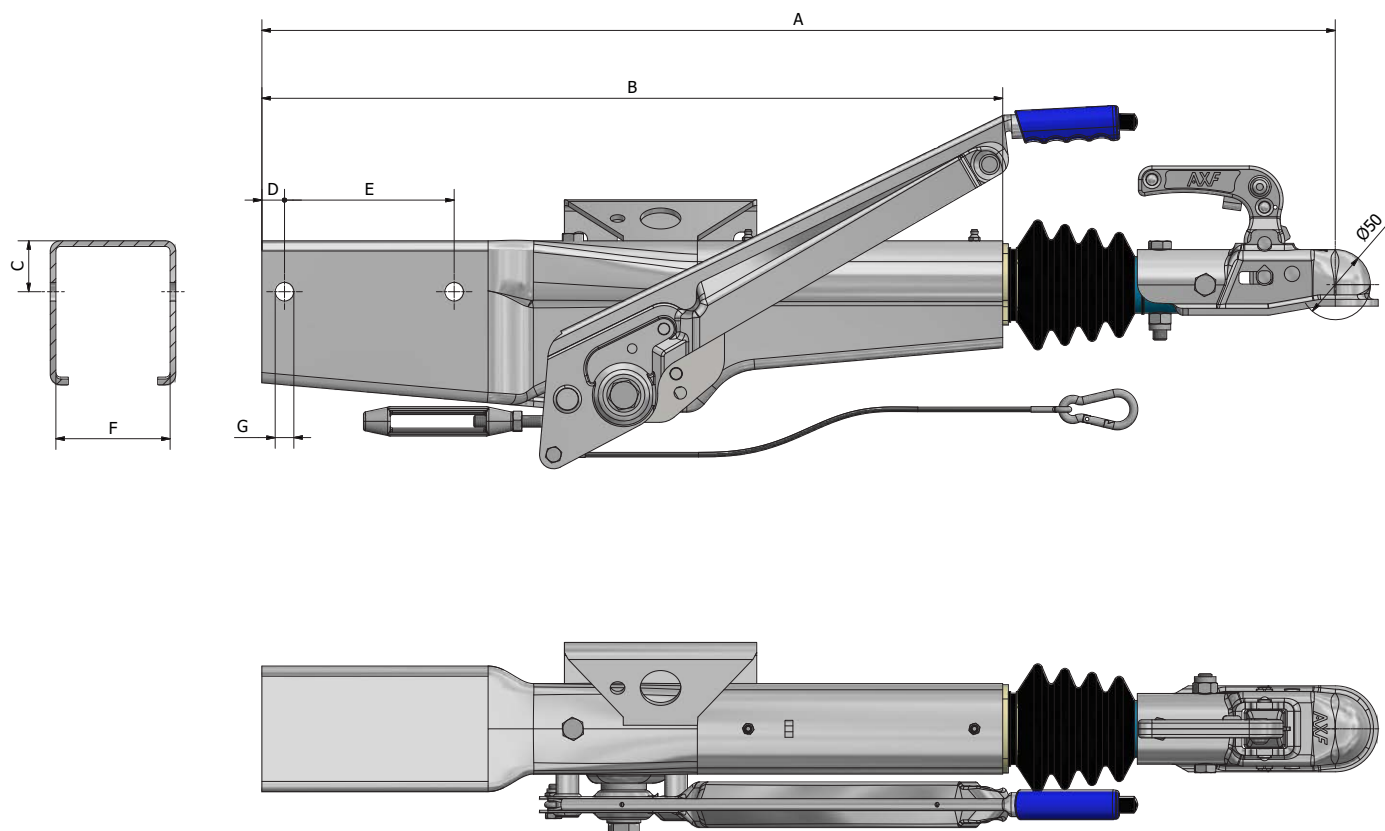

### REPULSORE QUADRO DISPOSITIFS À INERTIE TIMON DROIT

CODICE CODE	TIPO TYPE	PORTATA CAPACITÉ de charge [Kg]	S [Kg]	D [Kn]	A [mm]	B [mm]	C [mm]	D [mm]	E [mm]	F [mm]	ØG [mm]	N. OMOLOGAZIONE N° HOMOLOGATION	
RR10003460	TQ	650	1000	75	14,06	805	505	35	20	120	71	13,5	55R-016433
RR15003222	TQ	900	1500	100	14,06	805	505	35	20	120	71	13,5	55R-016433
RR18001061	TQ3	950	1800	150	18,5	945	655	40	20	150	101	16,5	55R01/07*2984*00
RR28002100	TQ2	1500	2800	100	26,26	945	655	40	20	150	101	16,5	55R-016436

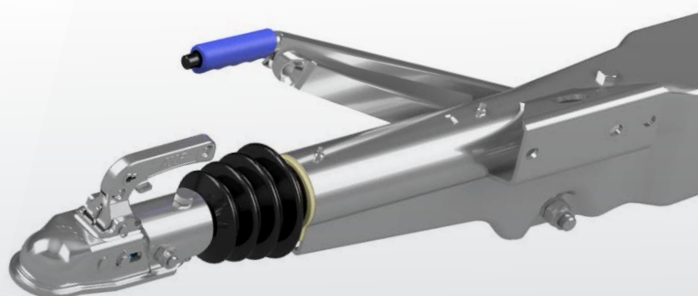



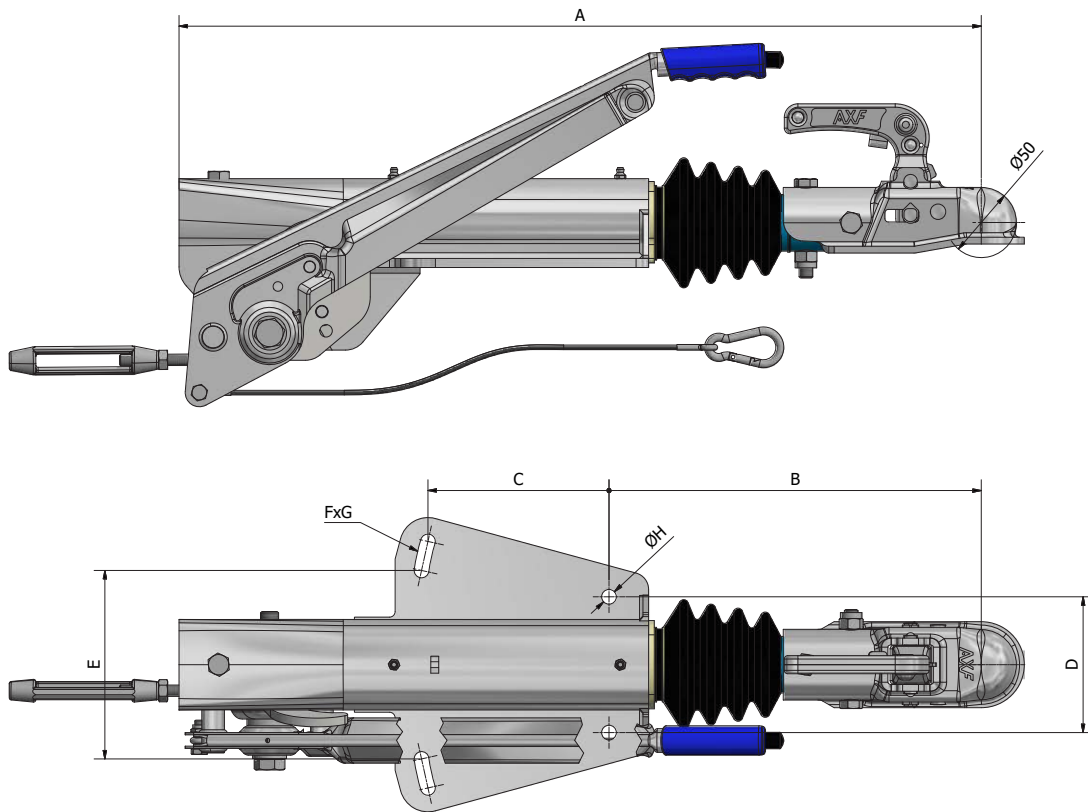

**REPULSORE V** DISPOSITIFS À INERTIE FLÈCHE EN V

CODICE CODE	TIPO TYPE	PORTATA CAPACITÉ de charge [Kg]	S [Kg]	D [Kn]	A [mm]	B [mm]	C [mm]	D [mm]	E [mm]	FxG [mm]	ØH [mm]	N. OMOLOGAZIONE N° HOMOLOGATION
RV10007568	TV	650 1000	75	14,95	605	320	125	100	148	13x18	13	55R-016435
RV15007570	TV	900 1500	100	14,95	605	320	125	100	148	13x18	13	55R-016435
RV18001395	TV3	950 1800	100	16,72	705	325	160	120	166	13x26	13	55R-016426
RV28002099	TV2	1500 2800	100	25,26	705	325	160	120	166	13x26	13	55R-016437





## RUOTINI - STAFFE

### ROUES JOCKEY - ÉTRIERS

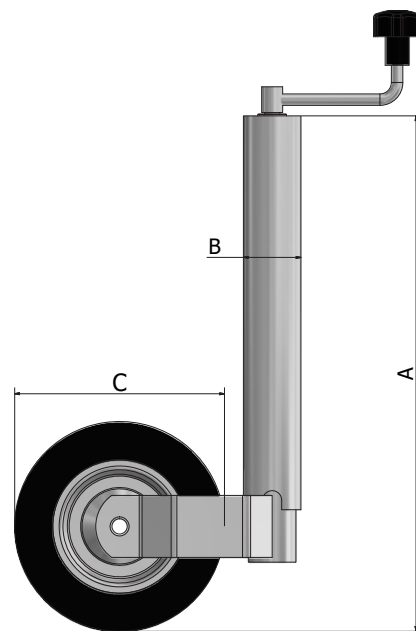

#### RUOTINI ROUES JOCKEY

CODICE CODE	PORTATA CAPACITÉ de charge [Kg]	A [mm]		B [mm]	C [mm]	PESO POIDS [Kg]
		MIN	MAX			
8800C07739	150	480	730	48	200	4
8800C10453	300	540	760	60	220	9

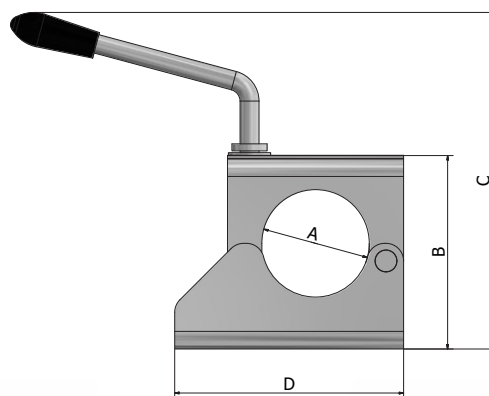

#### STAFFE ÉTRIERS

CODICE CODE	A [mm]	B [mm]	C [mm]	D [mm]	PESO POIDS [Kg]
8800C07735	48	68	140	128	1
8800C10454	60	101	178	128	1,5

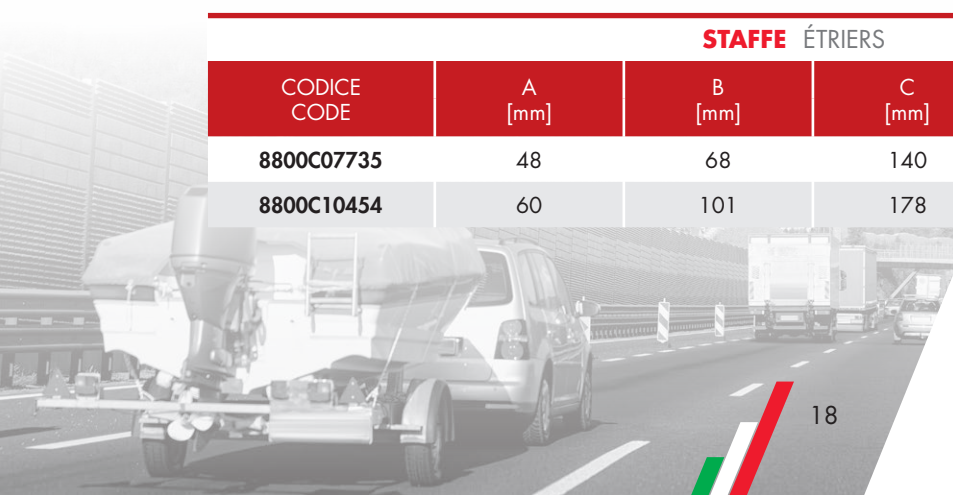

## SUPPORTO TECNICO SUPPORT TECHNIQUE

### QUALITÀ, RICERCA E INNOVAZIONE CON LA MASSIMA FLESSIBILITÀ. IL NOSTRO OBIETTIVO? LA COMPLETA SODDISFAZIONE DEL CLIENTE.

Con la nascita della divisione AXF, Frenco inserisce nel proprio organico nuove figure tecniche. Le nuove figure tecniche specializzate con software sempre all'avanguardia, nuovi strumenti di test, la collaborazione del controllo qualità, convalidano i prodotti standard, ne progettano e verificano di nuovi.

La continua ricerca di FRESCO della soddisfazione del cliente è stata trasferita anche nella divisione AXF.

AXF si impegna quotidianamente nella cura e soddisfazione della sua clientela.

La clientela, in fase di studio, può avvalersi del nostro supporto tecnico per l'adeguamento di prodotti esistenti o la progettazione di prodotti studiati ad hoc.

### QUALITÉ, RECHERCHE ET INNOVATION AVEC LA PLUS GRANDE FLEXIBILITÉ. NOTRE OBJECTIF? LA PLEINE SATISFACTION DU CLIENT.

Avec la naissance de la division AXF, Frenco intègre dans son effectif de nouvelles ressources techniques.

Les nouvelles ressources techniques spécialisées travaillent avec des logiciels de plus en plus avant-gardistes, de nouveaux instruments de test, la collaboration du contrôle qualité, valident les produits standard, en conçoivent et en vérifient de nouveaux.

La recherche continue de la satisfaction du client de la part de FRESCO a également été transférée dans la division AXF.

AXF s'engage quotidiennement dans le soin et la satisfaction de la clientèle.

La clientèle, en phase d'étude, peut faire appel à notre support technique pour l'adaptation de produits existants ou la conception de produits étudiés pour une finalité précise.

Tipo: Fattore di sicurezza  
Unità di  
10/11/2017, 11:18:56

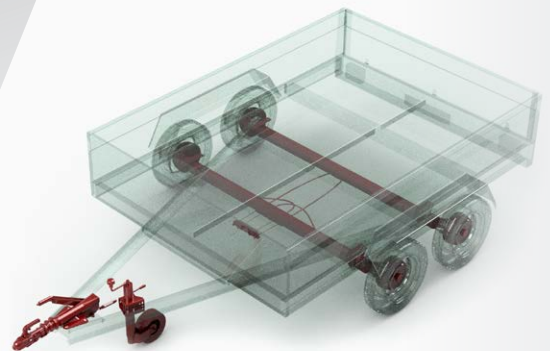
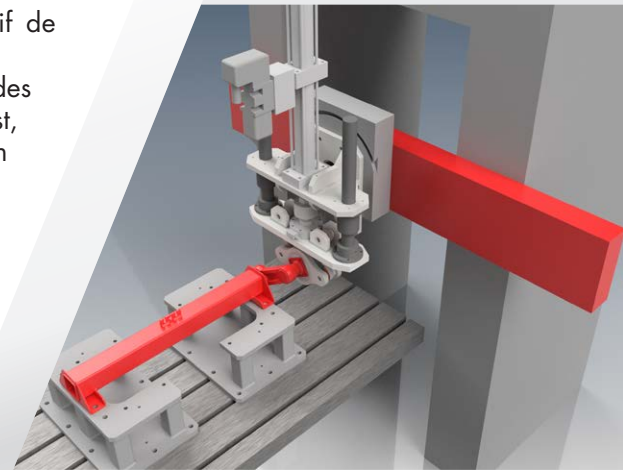
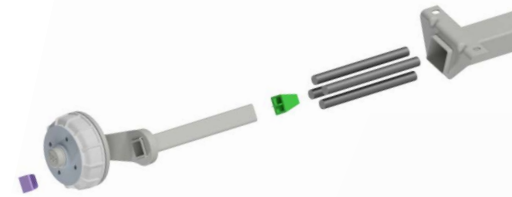
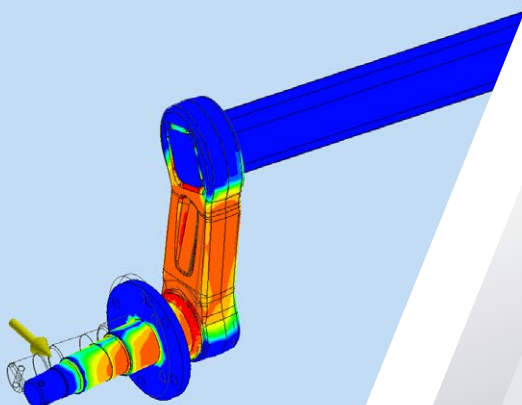
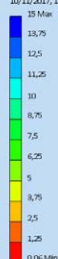

The logo consists of the letters 'A', 'X', and 'F' in a bold, sans-serif font. The 'X' is a solid red color, while the 'A' and 'F' are black. The letters are closely spaced and have a slight shadow effect.

AXLES DIVISION

[www.axf-axles.com](http://www.axf-axles.com)

The logo features the word 'FRENCO' in a bold, sans-serif font. The 'O' is a solid red color, while the other letters are black. The letters are closely spaced and have a slight shadow effect.

Frenco S.r.l. - Via Indipendenza 5/7 - 25018 Novagli di Montichiari (BS) ITALY  
Tel. +39 030 9981758 - Fax +39 030 9981779 - [info@frencosrl.it](mailto:info@frencosrl.it) - [www.frenco-italy.com](http://www.frenco-italy.com)